

LD-80

USER'S GUIDE



P
英
LD80-E-2

CASIO®

GUIDELINES LAID DOWN BY FCC RULES FOR USE OF THE UNIT IN THE U.S.A. (not applicable to other areas).

NOTICE

This equipment has been tested and found to comply with the limits for a Class B digital device, pursuant to Part 15 of the FCC Rules. These limits are designed to provide reasonable protection against harmful interference in a residential installation. This equipment generates, uses and can radiate radio frequency energy and, if not installed and used in accordance with the instructions, may cause harmful interference to radio communications. However, there is no guarantee that interference will not occur in a particular installation. If this equipment does cause harmful interference to radio or television reception, which can be determined by turning the equipment off and on, the user is encouraged to try to correct the interference by one or more of the following measures:

- Reorient or relocate the receiving antenna.
- Increase the separation between the equipment and receiver.
- Connect the equipment into an outlet on a circuit different from that to which the receiver is connected.
- Consult the dealer or an experienced radio/TV technician for help.

FCC WARNING

Changes or modifications not expressly approved by the party responsible for compliance could void the user's authority to operate the equipment.

Welcome...

To the happy family of satisfied CASIO electronic musical instrument owners! To get the most out of the many features and functions of this musical instrument, be sure to carefully read this manual and keep it on hand for future reference.

Important!

Please note the following important information before using this product.

- Before using the optional AD-12 AC Adaptor to power the unit, be sure to check the AC adaptor for any damage first. Carefully check the power cord for breakage, cuts, exposed wire and other serious damage. Never let children use an AC adaptor that is seriously damaged.
- Never attempt to recharge batteries.
- Do not use rechargeable batteries.
- Never mix old batteries with new ones.
- Use recommended batteries or equivalent types.
- Always make sure that positive (+) and negative (-) poles are facing correctly as indicated near the battery compartment.
- Replace batteries as soon as possible after any sign they are getting weak.
- Do not short-circuit the battery terminals.
- The product is not intended for children under 3 years.
- Use only the following CASIO AC adaptor: AD-12.

- The AC adaptor is not a toy.
- Be sure to disconnect the AC adaptor before cleaning the product.



CASIO ELECTRONICS CO., LTD.
Unit 6, 1000
North Circular Road
London NW2 7JD, U.K.

This mark is valid in the EU countries only.
Please keep all information for future reference.

Main Features

LIGHTING GUIDE SYSTEM

A light on each pad and the pedal indicators flash to let you know when it's time to strike the pad or press the pedal.

Touch Response

The volume and timbre of the sound produced is varied in accordance with how hard you strike a pad. This makes it possible to add a wide range of nuances to your percussion play.

7 pads

Select from among 20 different drum sets or specify a particular drum sound you want to assign to a pad.

100 versatile rhythms

Select from among 100 different preset rhythms, including rock, jazz, and much more.

Informative display screen

An easy-to-understand display screen provides you with a wealth of information about the Digital Drum's operations.

Super Bass

The press of a button enhances low range sounds, making them more powerful and realistic.

Recording function

You can record up to 300 notes in memory for later playback.

Metronome

Select either a simulated human voice or click sound as a reference beat.

Foot pedals

A pair of foot pedals provides realistic hi-hat and bass drum play.

Safety Precautions

Symbols

Various symbols are used in this user's guide and on the product itself to ensure that the product is used safely and correctly, and to prevent injury to the user and other persons as well as damage to property. Those symbols along with their meanings are shown below.

DANGER

This symbol indicates information that, if ignored or applied incorrectly, creates the danger of death or serious personal injury.

WARNING

This indication stipulates matters that have the risk of causing death or serious injury if the product is operated incorrectly while ignoring this indication.

CAUTION

This indication stipulates matters that have the risk of causing injury as well as matters for which there is the likelihood of occurrence of physical damage only if the product is operated incorrectly while ignoring this indication.

Symbol Examples



This triangle symbol () means that the user should be careful. (The example at left indicates electrical shock caution.)



This circle with a line through it () means that the indicated action must not be performed. Indications within or nearby this symbol are specifically prohibited. (The example at left indicates that disassembly is prohibited.)



The black dot () means that the indicated action must be performed. Indications within this symbol are actions that are specifically instructed to be performed. (The example at left indicates that the power plug must be unplugged from the electrical socket.)

DANGER

Alkaline Batteries

Perform the following steps immediately if fluid leaking from alkaline batteries ever gets into your eyes. 

1. Do not rub your eyes! Rinse them with water.
2. Contact your physician immediately.

Leaving alkaline battery fluid in your eyes can lead to loss of sight.

WARNING



Smoke, Strange Odor, Overheating

Continued use of the product while it is emitting smoke, a strange odor, or heat creates the risk of fire and electric shock. Take the following steps immediately.

1. Turn off power.
2. If you are using the AC adaptor for power, unplug it from the wall outlet.
3. Contact your original retailer or an authorized CASIO Service Provider.

AC Adaptor

Misuse of the AC adaptor creates the risk of fire and electric shock. Always make sure you observe the following precautions.

- Be sure to use only the AC adaptor that is specified for this product.
- Use only a power source whose voltage is within the rating marked on the AC adaptor. 
- Do not overload electrical outlets and extension cords. 

AC Adaptor

Misuse of the AC adaptor's electric cord can damage or break it, creating the risk of fire and electric shock. Always make sure you observe the following precautions.

- Never place heavy objects on the cord or subject it to heat.
- Never try to modify the cord or subject it to excessive bending.
- Never twist or stretch the cord.
- Should the electric cord or plug become damaged, contact your original retailer or authorized CASIO Service Provider.



AC Adaptor

Never touch the AC adaptor while your hands are wet. Doing so creates the risk of electric shock.



Batteries

Misuse of batteries can cause them to leak, resulting in damage to nearby objects, or to explode, creating the risk of fire and personal injury. Always make sure you observe the following precautions.

- Never try to take batteries apart or allow them to become shorted.
- Never expose batteries to heat or dispose of them by incineration.
- Never mix old batteries with new ones.
- Never mix batteries of different types.
- Do not charge the batteries.
- Make sure the positive (+) and negative (-) ends of the batteries are facing correctly.



Do not incinerate the product.

Never throw the product into fire.

Doing so can cause it to explode, creating the risk of fire and personal injury.



Water and Foreign Matter

Water, other liquids, and foreign matter (such as pieces of metal) getting into the product create the risk of fire and electric shock. Take the following steps immediately.

1. Turn off power.
2. If you are using the AC adaptor for power, unplug it from the wall outlet.



3. Contact your original retailer or an authorized CASIO Service Provider.

Disassembly and Modification

Never try to take this product apart or modify it in any way. Doing so creates the risk of electric shock, burn injury, or other personal injury. Leave all internal inspection, adjustment, and maintenance up to your original retailer or authorized CASIO Service Provider.



Dropping and Impact

Continued use of this product after it has been damaged by dropping or subjecting it to strong impact creates the risk of fire and electric shock. Take the following steps immediately.

1. Turn off power.
2. If you are using the AC adaptor for power, unplug it from the wall outlet.
3. Contact your original retailer or an authorized CASIO Service Provider.



Plastic Bags

Never place the plastic bag the product comes in over your head or in your mouth. Doing so creates the risk of suffocation. Particular care concerning this precaution is required where small children are present.



Location

Avoid locating the product on an unstable stand, on an uneven surface, or any other unstable location. An unstable location can cause the product to fall over, creating the risk of personal injury.



CAUTION

AC Adaptor

Misuse of the AC adaptor creates the risk of fire and electric shock. Always make sure you observe the following precautions.

- Do not locate the electric cord near a stove or other sources of heat.
- Never pull on the cord when unplugging from the electrical outlet. Always grasp the AC adaptor when unplugging.



AC Adaptor

Misuse of the AC adaptor creates the risk of fire and electric shock. Always make sure you observe the following precautions.

- Insert the AC adaptor into the wall outlet as far as it will go.
- Unplug the AC adaptor from the wall outlet during lightening storms or before leaving on a trip or other long-term absence.
- At least once a year, unplug the AC adaptor from the wall outlet and wipe away any dust that is built up in the area around the prongs of the plug.



Relocating the Product

Before relocating the product, always unplug the AC adaptor from the wall outlet and disconnect all other cables and connecting cords. Leaving cords connected creates the risk of damage to the cords, fire, and electric shock.



Cleaning

Before cleaning the product, always unplug the AC adaptor from the wall outlet first. Leaving the AC adaptor plugged in creates the risk of damage to the AC adaptor, fire, and electric shock.



Batteries

Misuse of batteries can cause them to leak, resulting in damage to nearby objects, or to explode, creating the risk of fire and personal injury. Always make sure you observe the following precautions.

- Use only batteries that are specified for use with this product.
- Remove batteries from the product if you do not plan to use it for a long time.



Connectors

Connect only the specified devices and equipment to the product's connectors. Connection of a non-specified device or equipment creates the risk of fire and electric shock.



Location

Avoid the following locations for this product. Such locations create the risk of fire and electric shock.

- Areas subject to high humidity or large amounts of dust
- In food preparation areas or other areas subject to oil smoke
- Near air conditioning equipment, on a heated carpet, in areas exposed to direct sunlight, inside of a vehicle parked in the sun, or any other area that subjects the product to high temperatures



Sound Volume

Do not listen to music at very loud volumes for long periods. Particular care concerning this precaution is required when using headphones. High volume settings can damage your hearing.



Heavy Objects

Never place heavy object on top of the product. Doing so can make the product top heavy, causing the product to tip over or the object to fall from it, creating the risk of personal injury.



Care of your Instrument

Avoid heat, humidity or direct sunlight.

Do not overexpose the instrument to direct sunlight, or place it near an air conditioner, or in any extremely hot place.

Do not use near a TV or radio.

This instrument can cause video or audio interference with TV and radio reception. If this happens, move the instrument away from the TV or radio.

Do not use lacquer, thinner or similar chemicals for cleaning.

Clean the instrument with a soft cloth dampened in a weak solution of water and a neutral detergent. Soak the cloth in the solution and squeeze until it is almost dry.

Avoid use in areas subjected to temperature extremes.

Important!

When using batteries, be sure to replace them or shift to one of the alternate power sources whenever you notice any of the following symptoms.

- Instrument does not turn on
- Dim, difficult to read display
- Abnormally low speaker/headphone volume
- Distortion of sound output
- Occasional interruption of sound when playing at high volume
- Sudden power failure when playing at high volume
- Dimming of the display when playing at high volume
- Abnormal rhythm pattern and demo tune play
- Dimming of digital drum lights when notes sound

Contents

Welcome	E-1	Using Rhythms	E-18
Important!	E-1	Selecting a Rhythm	E-18
Main Features	E-2	Starting and Stopping Rhythm Play	E-18
Safety Precautions	E-3	Adjusting Accomp volume	E-19
Care of your Instrument	E-6	Adjusting the Rhythm Tempo	E-19
Contents	E-7	Turning Rhythm Parts On and Off	E-19
General Guide	E-8	Other Settings	E-20
Rear Panel	E-8	Using Reverb	E-20
Control Panel	E-9	Using Super Bass	E-20
Connections	E-10	Using the Metronome	E-20
Phones/Output Jack	E-10	Using the LIGHTING GUIDE SYSTEM	E-21
Accessories and Options	E-10	Recording	E-22
Connecting the Foot Pedals	E-11	MIDI	E-23
Power Supply	E-12	What is MIDI?	E-23
Using Batteries	E-12	MIDI Terminals	E-23
Using the AC Adaptor	E-13	What you can do with MIDI	E-23
Basic Operations	E-14	Troubleshooting	E-24
Adjusting Main volume	E-14	Specifications	E-25
Playing the Demo Tune	E-14	Reference	A-1
Playing the Drum Pads	E-15	Percussion Sound List	A-1
Initial Default Setup	E-15	Drum Set List	A-2
Selecting a Drum Set	E-16	Rhythm List	A-3
Configuring a Custom Drum Set	E-16	MIDI Implementation Chart	

General Guide

- Names of keys, buttons, and other items are indicated in the text of this manual using bold type.

■ Rear Panel

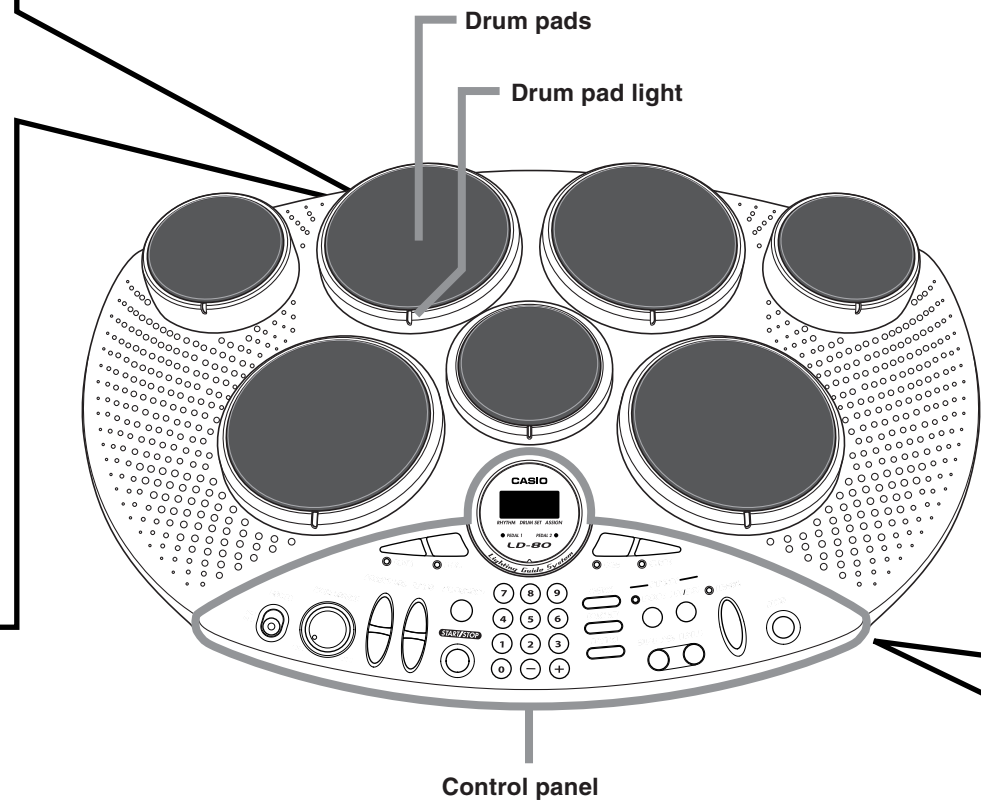
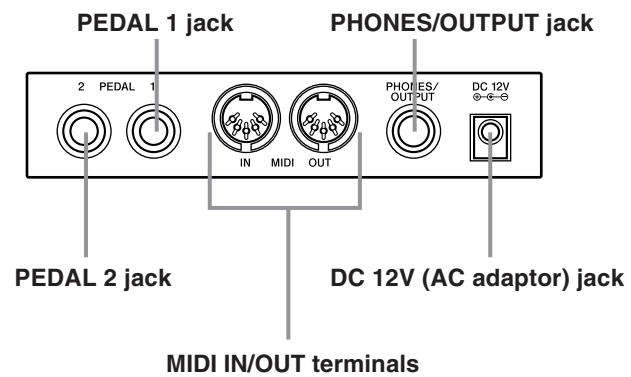

Control Panel

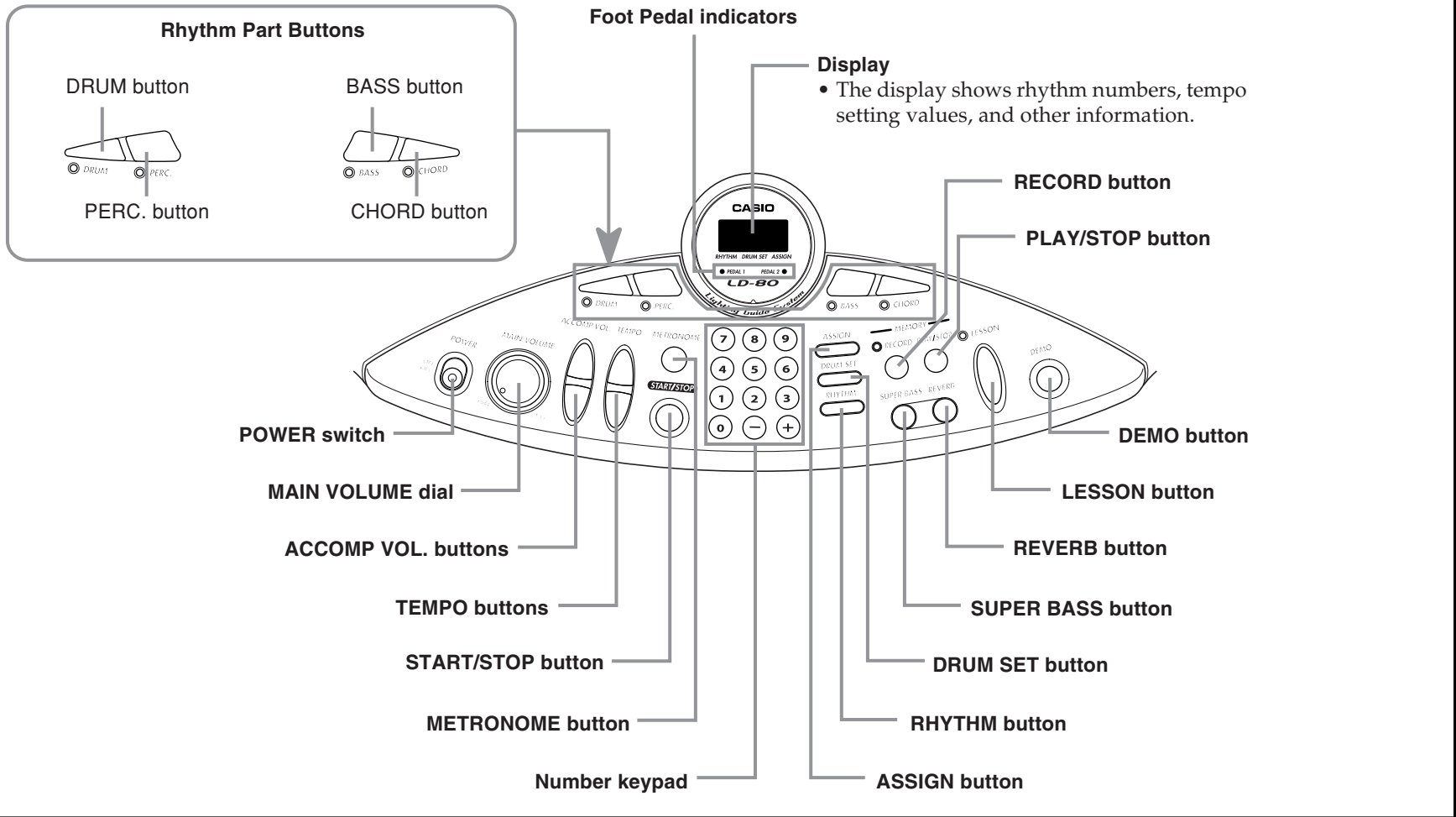

Connections

The following describes how to connect external equipment to the Digital Drum's PHONES/OUTPUT jack. See "MIDI" on page E-23 for information about connecting to another MIDI device.

- Make sure you turn off all equipment before making any connections.

■ Phones/Output Jack

Before connecting headphones or other external equipment, be sure to first turn down the volume settings of the digital drum and the connected equipment. You can then adjust volume to the desired level after connections are complete.

Rear Panel

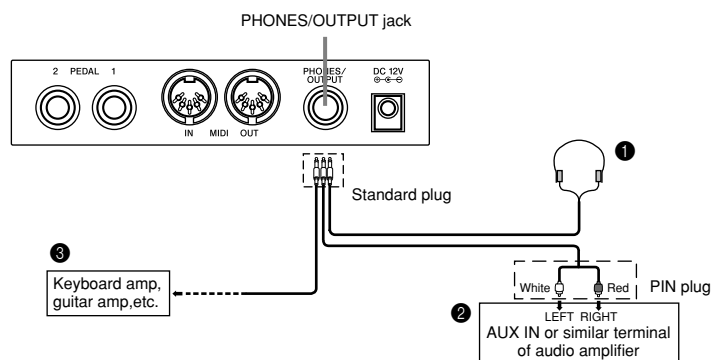

Connecting Headphones (1)

Connecting headphones cuts off output from the digital drum's built-in speakers, so you can play even late at night without disturbing anyone.

Audio Equipment (2)

Connect the digital drum to an audio equipment using a commercially available connecting cord with a standard plug on one end and two PIN plugs on the other end. In this configuration, you normally set the input selector of the audio equipment to the terminal (usually marked AUX IN or something similar) where the cord from the digital drum is connected. See the user documentation that comes with your audio equipment for full details.

Musical Instrument Amplifier (3)

Use a commercially available connecting cord to connect the digital drum to a musical instrument amplifier.

NOTE

- Be sure to use a connecting cord that has standard plugs on the ends you connect to the digital drum and amplifier.

Connection Example

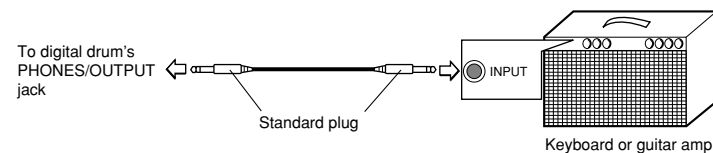

■ Accessories and Options

Use only the accessories and options specified for this digital drum. Use of non-authorized items creates the danger of fire, electrical shock, and personal injury.

■ Connecting the Foot Pedals

Your Digital Drum comes with two foot pedals that you can connect to the PEDAL 1 and PEDAL 2 jacks.

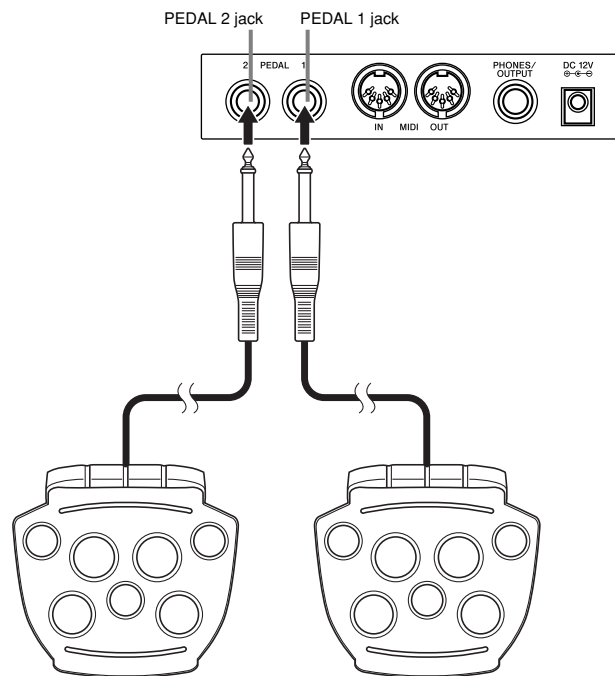

- See “Foot Pedal Assignments” on page E-15 for information about how to use the foot pedals while playing the Digital Drum.

Important!

- Turn off power before connecting the foot pedals.
- Do not hold down either of the foot pedals while connecting them to the Digital Drum.

Power Supply

Your Digital Drum can run under battery power or under power supplied by an optional AC adaptor.

■ Using Batteries

Always make sure you turn off the Digital Drum before loading or replacing batteries.

To load batteries

1. Carefully turn over the Digital Drum, and remove the battery compartment cover.
2. Load six C-size (LR14) batteries into the battery compartment.
 - Make sure that the positive (+) and negative (-) ends of the batteries are facing correctly.

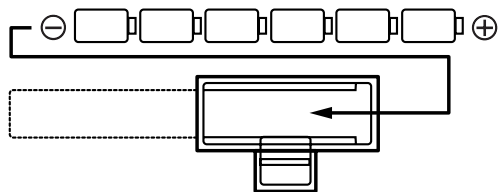

3. Insert the tabs of the battery compartment cover into the holes provided and close the cover.
 - The Digital Drum may not function correctly if you load or replace batteries with power turned on. If this happens, turning the Digital Drum off and then back on again should return functions back to normal.

Important Battery Information

- The following shows the approximate battery life provided by different battery types.
 - Standard battery life: Approximately 5 hours (LR14)The above value is standard battery life at normal temperature, with the digital drum volume at a medium setting. Temperature extremes or playing at very loud volume settings can shorten battery life.
- Any of the following symptoms indicate low battery power. Replace batteries as soon as possible whenever any of the following occurs.
 - Instrument does not turn on
 - Dim, difficult to read display
 - Abnormally low speaker/headphone volume
 - Distortion of sound output
 - Occasional interruption of sound when playing at high volume
 - Sudden power failure when playing at high volume
 - Dimming of the display when playing at high volume
 - Abnormal rhythm pattern and demo tune play
 - Dimming of digital drum lights when notes sound

Caution!

Improper handling of batteries can cause them to burst and leak, which creates the danger of personal injury or damage due to contact with battery acid. Be sure to note the following important precautions.

- Always make sure that the positive (+) and negative (-) poles are facing correctly as indicated inside the battery compartment.
- To avoid damage caused by leaking batteries, be sure to remove batteries from the Digital Drum whenever you leave it unattended for long periods (such as when leaving on a trip).
- Never mix batteries of different types.
- Never mix old batteries with new ones.
- Never discard batteries by incinerating them, do not allow their poles to be shorted (connected to each other), never take batteries apart, and do not expose batteries to direct heat.
- Replace batteries as soon as possible after any sign they are getting weak.
- Never attempt to recharge batteries.

■ Using the AC Adaptor

Make sure you use only the AC adaptor specified for this Digital Drum.

Specified AC Adaptor: AD-12

Also note the following important warnings and precautions when using the AC adaptor.

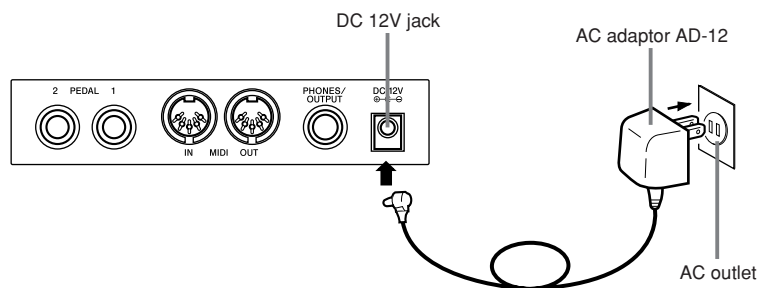

Warning!

- Take care to avoid any damage to or breakage of the power cord. Never place any heavy objects on the power cord or expose it to direct heat. Doing so creates the danger of power cord damage, fire, and electrical shock.
- Use only the specified AC adaptor. Use of another type of adaptor creates the danger of fire and electrical shock.

Caution!

- For safety sake, be sure to unplug the AC adaptor from the wall outlet whenever leaving the digital drum unattended for a long time (such as when leaving on a trip).
- Always turn off the digital drum and unplug the AC adaptor from the wall outlet when you are not using the digital drum.

Important!

- Make sure that the digital drum is turned off before connecting or disconnecting the AC adaptor.
- Using the AC adaptor for a long time can cause it to become warm to the touch. This is normal and does not indicate malfunction.

NOTE

- Output volume under battery power may be lower than volume under AC adaptor power. If you feel that output volume under battery power is too low, switch to AC adaptor power.

Basic Operations

This section provides the most basic information you need to get your Digital Drum running.

To turn power on and off

Slide the POWER switch up and down to turn power ON and OFF.

■ Adjusting Main volume

Rotate the MAIN VOLUME dial to adjust overall volume, including non-drum sounds, rhythms, metronome, etc.

- Rotate the MAIN VOLUME dial left to decrease main volume, or right to increase it.

■ Playing the Demo Tune

The demo tune provides you with a demonstration of the various capabilities of your Digital Drum.

To start and stop demo tune play

Press the DEMO button to start and stop demo tune play. You can also stop demo tune play by pressing the START/STOP button.

- You can use the TEMPO buttons to adjust the speed of the demo tune while it is playing. Stopping demo tune play returns the demo tune to its initial default tempo.
- You can use the rhythm part buttons to turn the DRUM, PERC., BASS, and CHORD parts of the demo tune off or on while it is playing.

Playing the Drum Pads

You can select from among 20 different drum sets for the seven pads and two pedals. Strike a pad to play the percussion sound assigned to it. The volume of the sound produced when you strike a drum pad depends on how much force you use, and the area of the drum pad that you strike.

■ Initial Default Setup

Drum set 001 is always selected whenever you first turn on the Digital Drum. The following shows the particular percussion sounds that are assigned to each drum pad with Drum set 001.

Drum Assignments (Drum set 001)

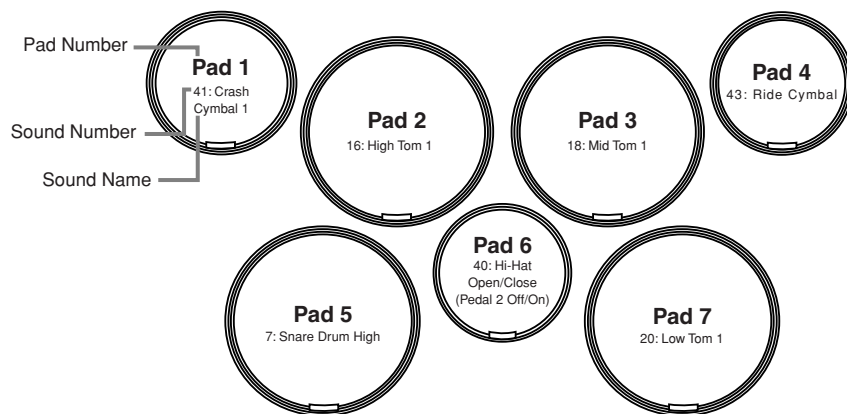

- Example: Drum Set 001 Standard 1

Foot Pedal Assignments (Drum set 001)

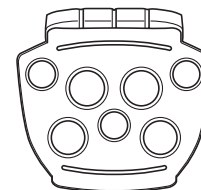

Pedal 1
 Pedal Released: Hi-hat open
 Pedal Pressed: Hi-hat closed

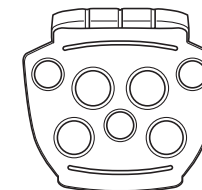

Pedal 2
 Press to sound "1: Bass Drum Low."

- Striking the pad with the foot pedal depressed produces a closed hi-hat sound.
- Striking the pad with the foot pedal not pressed produces an open hi-hat sound.
- Pressing the foot pedal without striking the pad produces a hi-hat pedal sound.
- See "Drum Set List" on page A-2 for a list of available drum sets and their contents.

■ Selecting a Drum Set

The percussion sounds that make up the drum set you select are assigned to the seven drum pads and two foot pedals. See “Drum Set List” on page A-2 for a list of available drum sets and their contents.

To select a drum set

1. Press the **DRUM SET** button.
 - The DRUM SET indicator lights and the currently selected drum set’s number appears on the display.



2. Use the number pad to input the number of the drum set you want to use.
 - Input a two-digit number. To specify Drum Set 08, for example, press [0] and then [8].
 - You can also use the (+) and (-) keys to scroll through numbers on the display. Scrolling past drum set number 020 displays “CU,” which indicates the custom drum set. Holding down (+) or (-) scrolls at high speed.
 - Make sure you always input a two-digit number in the range of 01 to 20.

■ Configuring a Custom Drum Set

Your Digital Drum comes with 76 high-quality percussion sounds that you can assign to any one of the seven drum pads and two foot pedals. This way you can configure your own custom drum set that consists of the percussion sounds you want.

- See “Percussion Sound List” on page A-1 for more information about percussion sounds.

To configure a custom drum set

1. Select the drum set you want to start from.
 - See “To select a drum set” on this page.
2. Press the **ASSIGN** button.



- The first percussion sound number that appears is the sound currently assigned to Pad 1. The Pad 1 light is lit at this time.
3. Strike the pad or press the pedal to which you want to assign a new sound.
 - To change the percussion sound assigned to Pad 7, for example, strike Pad 7. This causes the pad’s light to light, and the percussion sound currently assigned to the pad appears on the display.
 - The foot pedal indicator lights in the case of the foot pedal.

4. Use either of the following techniques to assign the percussion sound you want to the pad you selected in step 3 (Pad 7 in our example).
 - Strike the drum pad to scroll through percussion sounds sequentially. Each strike advances to the next sound and plays it.
 - Use the number pad to input a two-digit sound number. You can also use the (+) and (-) keys to scroll through numbers on the display. Holding down (+) or (-) scrolls at high speed.
 - See "Percussion Sound List" on page A-1 for information on the percussion sounds you can assign to a drum pad or pedal.
5. Repeat steps 3 through 4 for another pad or pedal, if you want.
6. After all the assignments are the way you want, press the **DRUM SET** button to store your custom drum set.



7. Play your new custom drum set.

To select the custom drum set

1. Perform the procedure under "To select a drum set" on page E-16.
2. In step 2, use the (+) and (-) keys to scroll through the drum set numbers until "CU" (CUSTOM) appears on the display.
 - "CU" is located between drum set number 020 and drum set number 001 (... 019 ↔ 020 ↔ CU ↔ 001 ↔ ...).

NOTE

- The custom drum set remains in memory even when the Digital Drum is turned off.
- The default data assigned to the custom drum set is the same as drum set 001.

Using Rhythms

This section explains how to select accompaniment rhythms and control their playback.

■ Selecting a Rhythm

Use the following procedure to select from among the 100 rhythm patterns built into your Digital Drum.

- See “Rhythm List” on page A-3 for a list of available rhythms and their rhythm numbers.

■ NOTE

- The initial default rhythm setting is 00 after you turn on Digital Drum power.

To select a rhythm

1. Press the **RHYTHM** button.
 - The RHYTHM indicator lights and the currently selected rhythm’s number appears on the display.

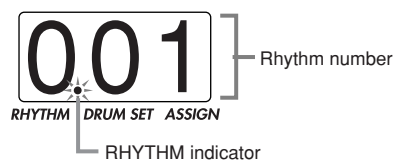

2. Use the number pad to input the number of the rhythm you want to use.
 - You can input a two-digit rhythm number, or use the (+) and (-) keys to scroll through numbers on the display. Holding down (+) or (-) scrolls at high speed.
 - Make sure you always input a two-digit number in the range of 00 to 99.

About rhythm types

- There are two types of rhythms: looped rhythms and fixed-length rhythms. Looped rhythms (rhythm numbers 00 to 79) keep playing in an endless loop until you stop them. Fixed-length rhythms (rhythm numbers 80 to 99) stop playing automatically when they reach their end.

■ Starting and Stopping Rhythm Play

Perform the following steps to start and stop rhythm play.

To start and stop rhythm play

1. Select the rhythm you want to play.
 - See “Selecting a Rhythm” on this page.
2. Press the **START/STOP** button to start rhythm play.
 - After a count that sounds like two drum sticks hitting together, the rhythm starts to play
 - The beat count value increments with each beat, cycling back to 1 each time the rhythm pattern restarts.
 - The ASSIGN indicator flashes for each beat. The RHYTHM, DRUM SET, and ASSIGN indicators all flash for the first beat of each measure.
3. If you want, you can use the number pad to change the rhythm number while rhythm play is in progress. See “To select a rhythm” on this page.
4. To stop rhythm play, press **START/STOP**.

■ Adjusting Accomp volume

The ACCOMP VOL. buttons control the volume level of the rhythm only. They do not affect the volume of sounds you play on the drum pads, so you can adjust Accomp volume to obtain good balance between your drum play and accompaniments.

- Note that the Accomp volume setting also affects the metronome (page E-20).

To adjust Accomp volume

Press the upper ACCOMP VOL. button to increase Accomp volume, or the lower button to decrease it.

- As soon as you press an ACCOMP VOL. button, the display changes to show the current Accomp volume setting as a value in the range of 0 (muted) to 9 (maximum).
- You can adjust Accomp volume while rhythm play is ongoing or stopped.
- Holding down either ACCOMP VOL. button changes the setting at high speed.

■ Adjusting the Rhythm Tempo

Perform the following steps to change the tempo (speed) of the rhythm. This setting also affects demo play (page E-14).

To adjust the rhythm tempo

Press the TEMPO button to display the current tempo setting.



- Press the upper TEMPO button to increase rhythm tempo, or the lower button to decrease it.
- As soon as you press a TEMPO button, the display changes to show the current tempo setting as a value in the range of 40 to 240.
- You can adjust tempo while rhythm play is ongoing or stopped.
- Holding down either TEMPO button changes the setting at high speed.

■ Turning Rhythm Parts On and Off

Rhythm parts are made up of four named DRUM (main drum track), PERC. (main percussion track), BASS (bass track), and CHORD (main chord track). You can turn off (mute) one or more part and play along with the remaining parts.

To turn rhythm parts on and off

Use the DRUM, PERC., BASS, and CHORD buttons to toggle the corresponding part (button indicator lit) and off (button indicator not lit).

- You can turn parts on and off while rhythm play is ongoing or stopped.

Other Settings

This section describes other settings you can use to make your Digital Drum play more enjoyable and realistic.

■ Using Reverb

You can select from among four different reverb depth levels to help make percussion sounds and rhythm play sound more dynamic.

To select a reverb depth

1. Press the **REVERB** button.



- The initial default reverb depth setting after you turn on the Digital Drum is r2.
- You need to perform step 2 within about three seconds after pressing the REVERB button.

2. Use the number pad to specify the reverb depth you want to use.
 - You can input a one-digit number, or use the (+) and (-) keys to scroll through numbers on the display.
 - You can specify a depth in the range of r0 (reverb off) through r3 (maximum reverb).

■ NOTE

- Reverb depth data is not sent or received as MIDI data.

■ Using Super Bass

Super Bass makes the sounds produced by the Digital Drum deeper and more powerful.

To turn Super Bass on and off

1. Press the **SUPER BASS** button.

E-20

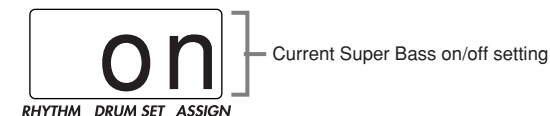

- The initial default setting after you turn on the Digital Drum is Super Bass on.

2. Press the **SUPER BASS** button again to turn Super Bass off.

■ Using the Metronome

The metronome gives you a reference beat you can use while practicing or playing. You can choose between two different metronome sounds: simulated human voice or click sound.

■ NOTE

- The metronome sound is not recorded when you perform a record operation (page E-22).

To start and stop the metronome

1. Press the **METRONOME** button once to start the simulated human voice metronome.
 - Beats are counted by a voice that says, "1-2-3-4."
2. Press the **METRONOME** button a second time to change to a click sound.
 - You can change the speed of the metronome sound using the TEMPO buttons.
 - You can adjust the volume of the metronome sound using the ACCOMP VOL. buttons.
3. To stop the metronome, press the **METRONOME** button a third time.

Using the LIGHTING GUIDE SYSTEM

The LIGHTING GUIDE SYSTEM of your Digital Drum provides you with a valuable Lesson tool that you can use to learn and play along with the preset rhythms.

To use the LIGHTING GUIDE SYSTEM

1. Select the rhythm you want to practice.
 - See "Using Rhythms" on page E-18.
2. Press the **LESSON** button so the indicator lamp above it is lit.
 - This automatically turns off the drum part.
3. Press the **START/STOP** button to start rhythm play.
4. Strike the pad in accordance with the lighting of their lights. Press the foot pedal when the foot pedal indicator lights.
5. To end the practice session, press the **LESSON** button.
 - This causes the indicator lamp above the button to turn off.

NOTE

- You can turn off rhythm parts during Lighting Guide practice, if you want. See "Turning Rhythm Parts On and Off" on page E-19.
- See "Using Rhythms" for information about making other rhythm settings (Accomp volume, tempo, etc.).
- You can not change the drum set selection or a custom drum set configuration while the indicator above the LESSON button is lit.

Recording

You can use the RECORD mode to record up to 300 notes in Digital Drum memory for later playback. The following is the type of data you can record in the RECORD mode.

- Drum pad and pedal operation data
- Rhythm (You cannot change rhythms while in the RECORD mode.)
- Rhythm part on/off settings
- Tempo setting (You cannot change the tempo setting while in the RECORD mode.)
- Accomp volume setting
- Reverb on/off setting

NOTE

- You cannot record MIDI data to memory.

To record

Important!

- Recording causes anything already in memory to be replaced by the new recording.
- Data remains in memory even when you turn off the Digital Drum.

1. Set up the Digital Drum for recording.
 - Select the rhythm and drum set you want to use, and make the tempo, part on/off, and reverb settings you want.
2. Press the **RECORD** button to enter the RECORD mode.
 - This causes the indicator lamp above the RECORD button to flash, indicating that the Digital Drum is in RECORD standby. To exit RECORD standby without recording anything at this point, press the RECORD button again.

3. Strike a pad or press the **START/STOP** button to start recording.
 - The indicator lamp above the RECORD button stops flashing to indicate that recording is in progress.
 - The metronome is turned on and sounds (but is not recorded) when you start recording. If you want to turn off the metronome, press the METRONOME button.
4. To stop recording, press the **START/STOP** or **RECORD** button.
 - This causes the indicator lamp above the RECORD button to turn off.
 - The message "FL" appears on the display and recording stops when memory becomes full.

To play back a recording

1. Press the **PLAY/STOP** button to play back data that is in memory.
2. Press **PLAY/STOP** again to stop playback.

MIDI

The MIDI IN and MIDI OUT terminals on the back of the Digital Drum provide expanded musical potential through the use of MIDI.

■ What is MIDI?

The letters “MIDI” stand for “Musical Instrument Digital Interface.” MIDI is a worldwide standard for digital signals and connectors that makes it possible for musical instruments and computers (devices) produced by different manufacturers to communicate with each other. For example, you could connect a MIDI tone generator to the Digital Drum’s MIDI OUT terminal and play the tone generator’s voices using the Digital Drum’s pads and pedals.

■ MIDI Terminals

The MIDI terminals of your Digital Drum are located on its rear panel.

MIDI IN

Data transmitted from the MIDI OUT terminal of another MIDI device is received at this terminal.

MIDI OUT

Digital Drum data can be transmitted from this terminal to the MIDI IN terminal of another MIDI device.

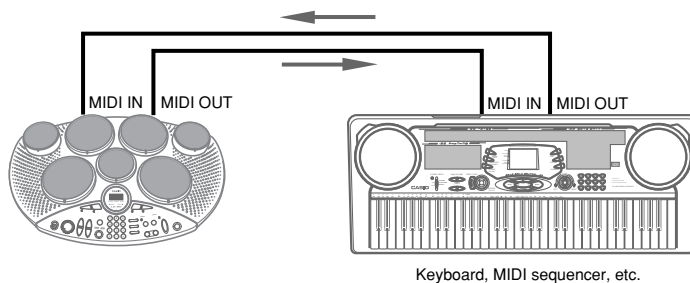

273A-E-025C

■ What you can do with MIDI

Connect the Digital Drum’s MIDI OUT terminal to a MIDI keyboard’s MIDI IN terminal.

This setup lets you use the Digital Drum’s pads and pedals to control the keyboard.

See NOTE, below, for details.

Connect the Digital Drum’s MIDI IN terminal to a MIDI keyboard’s MIDI OUT terminal.

With this setup, the Digital Drum acts as a tone generator played by keyboard operations.

Connect the Digital Drum’s MIDI OUT terminal to a MIDI sequencer’s MIDI IN terminal.

You can use this configuration to record output from the Digital Drum on an external MIDI sequencer.

Connect the Digital Drum’s MIDI IN terminal to a MIDI sequencer’s MIDI OUT terminal.

This configuration makes it possible to use sequencer data to drive the Digital Drum.

■ NOTE

- Drum pad lights do not light when MIDI data is played on the Digital Drum.
- You can use the pads and pedals to play the 76 percussion sounds* built into this keyboard. The percussion sounds have program change* and note numbers* assigned to them, which means that a message is sent from the keyboard’s MIDI terminal when you operate a pad or pedal.

* See the “Percussion Sound List” on page A-1 for details.

Troubleshooting

If this happens:	It could mean this:	So you should do this:	See page
No sound is produced when I strike a pad.	The Digital Drum is not being supplied power.	Check that batteries are loaded correctly, or that the AC adaptor is connected properly and plugged into an electrical outlet. Check for dead batteries.	Pages E-12,13
	Digital Drum power is not turned on.	Use the POWER switch to turn on power.	Page E-14
	Main volume setting is too low.	Adjust the main volume setting.	Page E-14
The Digital Drum does not produce any rhythm sound.	Accomp volume setting is too low.	Adjust the accomp volume setting.	Page E-19
The Digital Drum emits a loud sound and then stops working (under battery power).	Battery power is low.	Replace batteries with a full set of new ones, or use the AC adaptor for power.	Pages E-12, 13
Display screen characters are dim and difficult to read (under battery power).	Battery power is low.	Replace batteries with a full set of new ones, or use the AC adaptor for power.	Pages E-12, 13

Specifications

Model:	LD-80								
Drum Pads:	7, with Touch Response								
Lighting Guide System:	Lights indicate pad play during rhythm playback								
Sounds:	76 PCM drum voices								
Control Panel:	POWER; MAIN VOLUME; ACCOMP VOL.; TEMPO; START/STOP; number keypad; RHYTHM; DRUM SET; ASSIGN; LESSON; SUPER BASS; RECORD; PLAY/STOP; METRONOME; REVERB; DEMO; Rhythm Part buttons (DRUM, PERC., BASS, CHORD)								
Rhythms:	100								
Demos:	1								
Drum Sets:	20 preset + 1 Custom								
Tempo:	40 to 240								
Reverb:	4 depths r0 (off) to r3 (maximum)								
MIDI:	16 multi-timbre receive								
Speakers:	12 cm diameter x 2 (Output: 5W+5W)								
Terminals:	<table border="0"> <tr> <td>MIDI Terminals:</td> <td>IN, OUT</td> </tr> <tr> <td>Power Supply Terminal:</td> <td>DC 12V jack</td> </tr> <tr> <td>Headphones/Output Terminal:</td> <td>Stereo standard jack [output impedance: 100Ω, output voltage: 7.0V (RMS) MAX]</td> </tr> <tr> <td>Foot Pedal Terminals:</td> <td>Standard jack x 2</td> </tr> </table>	MIDI Terminals:	IN, OUT	Power Supply Terminal:	DC 12V jack	Headphones/Output Terminal:	Stereo standard jack [output impedance: 100Ω, output voltage: 7.0V (RMS) MAX]	Foot Pedal Terminals:	Standard jack x 2
MIDI Terminals:	IN, OUT								
Power Supply Terminal:	DC 12V jack								
Headphones/Output Terminal:	Stereo standard jack [output impedance: 100Ω, output voltage: 7.0V (RMS) MAX]								
Foot Pedal Terminals:	Standard jack x 2								
Power Supply:	<table border="0"> <tr> <td>2-way AC/DC power sources;</td> <td></td> </tr> <tr> <td>Batteries:</td> <td>6 C-size</td> </tr> <tr> <td>Battery life:</td> <td>approximately 5 hours on LR14 alkaline batteries</td> </tr> <tr> <td>AC adaptor:</td> <td>AD-12</td> </tr> </table>	2-way AC/DC power sources;		Batteries:	6 C-size	Battery life:	approximately 5 hours on LR14 alkaline batteries	AC adaptor:	AD-12
2-way AC/DC power sources;									
Batteries:	6 C-size								
Battery life:	approximately 5 hours on LR14 alkaline batteries								
AC adaptor:	AD-12								
Power Consumption:	12 V --- 18 W								
Dimensions:	60.0 x 38.5 x 13.0 cm (23 ⁵ / ₈ " x 15 ³ / ₁₆ " x 5 ¹ / ₈ ")								
Weight:	Approximately 3.5 kg (7.7 lbs) (without batteries)								

* Designs and specifications are subject to change without notice.

Reference

This section contains percussion sound lists, specifications, and other useful reference information.

Percussion Sound List

Percussion Sound No.	Sound Name	Program Change	Note No.
1	Kick Drum 2	0	35
2	Kick Drum 1	0	36
3	Power Kick	16	36
4	Electronic Bass Drum	24	36
5	Synth Bass Drum	25	36
6	Snare Drum 1	0	38
7	Snare Drum 2	0	40
8	Gated Snare Drum	16	38
9	Electronic Snare Drum Low	24	38
10	Electronic Snare Drum High	24	40
11	Synth Snare Drum	25	38
12	Brush Tap	40	38
13	Brush Swirl	40	40
14	Side Stick	0	37
15	Sticks	0	31
16	High Tom	0	50
17	High Mid Tom	0	48
18	Low Mid Tom	0	47
19	Low Tom	0	45
20	High Floor Tom	0	43
21	Low Floor Tom	0	41
22	Rock High Tom 1	16	50
23	Rock High Tom 2	16	48
24	Rock Mid Tom 1	16	47
25	Rock Mid Tom 2	16	45
26	Rock Low Tom 1	16	43
27	Rock Low Tom 2	16	41
28	Electronic High Tom 1	24	50
29	Electronic High Tom 2	24	48
30	Electronic Mid Tom 1	24	47

Percussion Sound No.	Sound Name	Program Change	Note No.
31	Electronic Mid Tom 2	24	45
32	Electronic Low Tom 1	24	43
33	Electronic Low Tom 2	24	41
34	Synth High Tom 1	25	50
35	Synth High Tom 2	25	48
36	Synth Mid Tom 1	25	47
37	Synth Mid Tom 2	25	45
38	Synth Low Tom 1	25	43
39	Synth Low Tom 2	25	41
40	*Hi-Hat Open/Closed	0	42
41	Crash Cymbal 1	0	49
42	Crash Cymbal 2	25	49
43	Ride Cymbal	0	51
44	Ride Bell	0	53
45	Chinese Cymbal	0	52
46	Splash Cymbal	0	55
47	Vibra-slap	0	58
48	Hand Clap	0	39
49	Tambourine	0	54
50	Cowbell	0	56
51	Synth Cowbell	26	56
52	Mute High Conga	0	62
53	Open High Conga	0	63
54	Low Conga	0	64
55	High Bongo	0	60
56	Low Bongo	0	61
57	High Timbale	0	65
58	Low Timbale	0	66
59	High Agogo	0	67
60	Low Agogo	0	68

Percussion Sound No.	Sound Name	Program Change	Note No.
61	Cabasa	0	69
62	Shaker	0	82
63	Claves	0	75
64	Mute Triangle	0	80
65	Open Triangle	0	81
66	Short Guiro	0	73
67	Long Guiro	0	74
68	Mute Cuica	0	78
69	Open Cuica	0	79
70	Mute Surdo	0	86
71	Open Surdo	0	87
72	Maracas	0	70
73	High-Q	0	27
74	Slap	0	28
75	Scratch Pull	0	29
76	Scratch Push	0	30

* Assigning "40: Hi-Hat Open/Closed" to both a pad and pedal makes it possible for this sound to be controlled by the foot pedals as described below.

- Striking the pad with the foot pedal depressed produces a closed hi-hat sound. (Program Change=0, Note No.=46)
- Striking the pad with the foot pedal not pressed produces an open hi-hat sound. (Program Change=0, Note No.=42)
- Pressing the foot pedal without striking the pad produces a hi-hat pedal sound. (Program Change=0, Note No.=44)

Drum Set List

Drum Set No.	Name	Pad 1		Pad 2		Pad 3		Pad 4		Pad 5	
		Sound No.	Sound Name	Sound No.	Sound Name	Sound No.	Sound Name	Sound No.	Sound Name	Sound No.	Sound Name
001	Standard 1	41	Crash Cymbal 1	16	High Tom 1	18	Mid Tom 1	43	Ride Cymbal	7	Snare Drum High
002	Standard 2	40	HH Open/Closed	17	High Tom 2	19	Mid Tom 2	41	Crash Cymbal 1	6	Snare Drum Low
003	Standard 3	41	Crash Cymbal 1	16	High Tom 1	18	Mid Tom 1	50	Cowbell	7	Snare Drum High
004	Standard 4	40	HH Open/Closed	16	High Tom 1	18	Mid Tom 1	41	Crash Cymbal 1	7	Snare Drum High
005	Standard 5	41	Crash Cymbal 1	17	High Tom 2	19	Mid Tom 2	50	Cowbell	7	Snare Drum High
006	Standard 6	46	Splash Cymbal	17	High Tom 2	19	Mid Tom 2	49	Tambourine	7	Snare Drum High
007	Standard 7	40	HH Open/Closed	16	High Tom 1	18	Mid Tom 1	43	Ride Cymbal	6	Snare Drum Low
008	Standard 8	40	HH Open/Closed	14	Side Stick	18	Mid Tom 1	44	Ride Bell	6	Snare Drum Low
009	Rock	41	Crash Cymbal 1	22	Rock High Tom 1	24	Rock Mid Tom 1	49	Tambourine	7	Snare Drum High
010	Heavy Metal	41	Crash Cymbal 1	23	Rock High Tom 2	25	Rock Mid Tom 2	50	Cowbell	8	Gated Snare Drum
011	Dance 1	40	HH Open/Closed	28	Electronic High Tom 1	30	Electronic Mid Tom 1	46	Splash Cymbal	10	Electronic Snare Drum High
012	Dance 2	45	Chinese Cymbal	29	Electronic High Tom 2	31	Electronic Mid Tom 2	73	High-Q	9	Electronic Snare Drum Low
013	Samba Perc.	68	Mute Cuica	59	High Agogo	60	Low Agogo	69	Open Cuica	70	Mute Surdo
014	Timbales	41	Crash Cymbal 1	46	Splash Cymbal	72	Maracas	7	Snare Drum High	58	Low Timbale
015	Conga	55	High Bongo	52	Mute High Conga	53	Open High Conga	56	Low Bongo	7	Snare Drum High
016	Synth	42	Crash Cymbal 2	34	Synth High Tom 1	36	Synth Mid Tom 1	51	Synth Cowbell	11	Synth Snare Drum
017	Brush	43	Ride Cymbal	17	High Tom 2	19	Mid Tom 2	41	Crash Cymbal 1	12	Brush Tap
018	Jazz	40	HH Open/Closed	16	High Tom 1	18	Mid Tom 1	43	Ride Cymbal	13	Brush Swirl
019	Ballad Perc.	62	Shaker	63	Claves	49	Tambourine	61	Cabasa	64	Mute Triangle
020	Cymbal	40	HH Open/Closed	41	Crash Cymbal 1	43	Ride Cymbal	44	Ride Bell	7	Snare Drum High

Drum Set No.	Name	Pad 6		Pad 7		Pedal 2		Pedal 1	
		Sound No.	Sound Name	Sound No.	Sound Name	Sound No.	Sound Name	Sound No.	Sound Name
001	Standard 1	40	HH Open/Closed	20	Low Tom 1	1	Bass Drum Low	40	HH Pedal
002	Standard 2	50	Cowbell	21	Low Tom 2	1	Bass Drum Low	40	HH Pedal
003	Standard 3	40	HH Open/Closed	20	Low Tom 1	2	Bass Drum High	40	HH Pedal
004	Standard 4	14	Side Stick	20	Low Tom 1	1	Bass Drum Low	40	HH Pedal
005	Standard 5	40	HH Open/Closed	21	Low Tom 2	1	Bass Drum Low	40	HH Pedal
006	Standard 6	40	HH Open/Closed	21	Low Tom 2	1	Bass Drum Low	40	HH Pedal
007	Standard 7	41	Crash Cymbal 1	20	Low Tom 1	1	Bass Drum Low	40	HH Pedal
008	Standard 8	41	Crash Cymbal 1	20	Low Tom 1	1	Bass Drum Low	40	HH Pedal
009	Rock	40	HH Open/Closed	26	Rock Low Tom 1	2	Bass Drum High	40	HH Pedal
010	Heavy Metal	40	HH Open/Closed	27	Rock Low Tom 2	3	MONDO Bass Drum	40	HH Pedal
011	Dance 1	48	Hand Clap	32	Electronic Low Tom 1	4	Electronic Bass Drum	40	HH Pedal
012	Dance 2	40	HH Open/Closed	33	Electronic Low Tom 2	4	Electronic Bass Drum	40	HH Pedal
013	Samba Perc.	61	Cabasa	71	Open Surdo	50	Cowbell	49	Tambourine
014	Timbales	50	Cowbell	57	High Triangle	1	Bass Drum Low	63	Claves
015	Conga	58	Low Timbale	54	Low Conga	1	Bass Drum Low	50	Cowbell
016	Synth	40	HH Open/Closed	38	Synth Low Tom 1	5	Synth Bass Drum	40	HH Pedal
017	Brush	40	HH Open/Closed	14	Side Stick	1	Bass Drum Low	40	HH Pedal
018	Jazz	62	Shaker	20	Low Tom 1	1	Bass Drum Low	40	HH Pedal
019	Ballad Perc.	46	Splash Cymbal	65	Open Triangle	50	Cowbell	74	Slap
020	Cymbal	46	Splash Cymbal	45	Chinese Cymbal	1	Bass Drum Low	40	HH Pedal

Rhythm List

Looped rhythms

Rhythm No.	Rhythm Name
8 Beat	
00	8 Beat 1
01	8 Beat 2
02	8 Beat 3
03	8 Beat 4
04	8 Beat 5
05	8 Beat Ballad 1
06	8 Beat Ballad 2
07	8 Beat Ballad 3
08	Soft Rock
09	Rock 1
10	Rock 2
11	Rock 3
12	Rock 4
13	Rock 5
14	Hard Rock 1
15	Hard Rock 2
16 Beat	
16	16 Beat 1
17	16 Beat 2
18	16 Beat 3
19	16 Beat 4
20	16 Beat 5
21	16 Beat 6
22	16 Beat 7
23	16 Beat Ballad 1
24	16 Beat Ballad 2
25	16 Beat Ballad 3
26	16 Beat Ballad 4
27	16 Beat Ballad 5

Rhythm No.	Rhythm Name
28	16 Beat Funk 1
29	16 Beat Funk 2
Dance	
30	Dance 1
31	Dance 2
32	Dance 3
33	Dance 4
34	Dance 5
35	Dance 6
Rap	
36	Rap 1
37	Rap 2
38	Rap 3
Bounce	
39	Bounce 1
40	Bounce 2
41	Bounce 3
Shuffle	
42	Shuffle 1
43	Shuffle 2
44	Shuffle 3
45	Shuffle 4
46	Shuffle 5
47	Shuffle 6
48	Shuffle 7
Slow Rock	
49	Slow Rock 1
50	Slow Rock 2
51	Slow Rock 3
52	Slow Rock 4

Rhythm No.	Rhythm Name
Latin	
53	Reggae 1
54	Reggae 2
55	Bossa Nova 1
56	Bossa Nova 2
57	Samba
58	Salsa
59	Latin Rock
60	Cha-Cha
61	Mambo
62	Rhumba 1
63	Rhumba 2
64	Afro Cuban
65	Tango
Swing	
66	Swing 1
67	Swing 2
68	Swing 3
Others	
69	Waltz
70	3/4 Ballad
71	Swing Blues
72	Blues
73	March 1
74	March 2
75	R&B
76	Hip-Hop
77	Funk
78	Country
79	Big Band

Fixed-length rhythms

Rhythm No.	Rhythm Name
8 Beat	
80	8 Beat 1
81	8 Beat 2
82	Ballad
83	Hard Rock 1
84	Hard Rock 2
85	Hard Rock 3
86	Pop Dance 1
87	Pop Dance 2
88	R&B
16 Beat	
89	16 Beat
90	Fusion
Funk	
91	Funk 1
92	Funk 2
Shuffle	
93	Shuffle 1
94	Shuffle 2
95	16 Beat Shuffle
96	16 Beat Triplet
Others	
97	Reggae
98	Bossa Nova
99	Big Band

Model **LD-80**

MIDI Implementation Chart

Version: 1.0

Function ...	Transmitted	Recognized	Remarks
Basic Channel			
Default Changed	10 10	1-16 1-16	
Mode			
Default Messages Altered	X X *****	Mode 3 Mode 3 *****	
Note Number:			
True voice	27-87 *****	1-127 1-127	
Velocity			
Note ON	O	O	
Note OFF	X	X	
After Touch			
Key's Ch's	X X	X X	
Pitch Bender			
	X	O	
Control Change			
1	X	O	Modulation
7	X	O	Volume
10	X	O	Pan
11	X	O	Expression
64	X	O	Hold1
66	X	O	Sostenuto
67	X	O	Soft pedal
80	X	O	Reverb Program
81	X	O	Chorus Program
91	X	O	Reverb send
93	X	O	Chorus send
120	X	O	All sound off
121	X	O	Reset all controller
123	X	O	All notes off
Program Change :			
True #	O *****	O *****	
System Exclusive			
	X	X	
System Common			
: Song Pos	X	X	
: Song Sel	X	X	
: Tune	X	X	
System Real Time			
: Clock	X	X	
: Commands	X	X	
Aux Messages			
: Local ON/OFF	X	X	
: All notes OFF	X	O	
: Active Sense	X	O	
: Reset	X	O	

Mode 1 : OMNI ON, POLY
Mode 3 : OMNI OFF, POLY

Mode 2 : OMNI ON, MONO
Mode 4 : OMNI OFF, MONO

O : Yes
X : No



This recycle mark indicates that the packaging conforms to the environmental protection legislation in Germany.

CASIO®

CASIO COMPUTER CO.,LTD.
6-2, Hon-machi 1-chome
Shibuya-ku, Tokyo 151-8543, Japan

MA0111-C (英) Printed in China
LD80-E-2

P